



7520 EAST MAIN STREET, LIMA NY 14485
 PH: 585-624-1990 - FAX: 585-624-2102
 WEB: WWW.LAKELANDSCONCRETE.COM
 E-MAIL: SALES@LAKELANDSCONCRETE.COM

DATE: 1/5/2021

DWG: SP-MK

AIRPORT
 MARKER
 2'-0" x 2'-0" x 0'-4"

DESIGN CRITERIA:

CONCRETE: 5000 PSI @ 28 DAYS
 ENTRAINED AIR: 5% - 9%
 REINFORCEMENT: BAR-ASTM A615 GR60
 WWR-ASTM A185

COMPONENT	WEIGHT (LBS)
MARKER	200

SPECIFICATIONS:

- LETTERS ARE TYPICALLY 5" TALL, CAN BE ANY SIZE OR FONT PER CUSTOMERS REQUEST
- THE PLAN VIEW (TEXT EXAMPLE) IS A COMMON MARKER, AND SHOWS THE MARKER AS IF IT WERE IN-FIELD, WITH TEXT. THE TEXT IS CUSTOM;

PLEASE WRITE IN THE DESIRED TEXT THAT YOU WOULD LIKE ON THE MARKER:

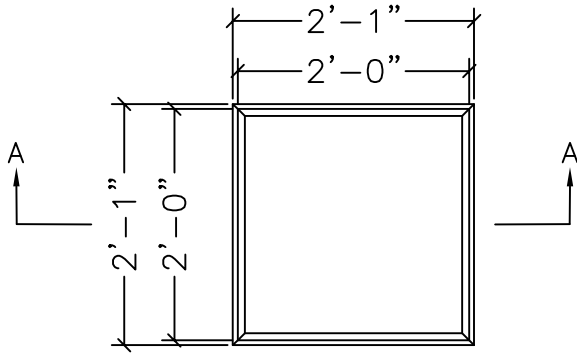

PLAN VIEW

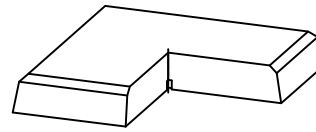

ISOMETRIC VIEW

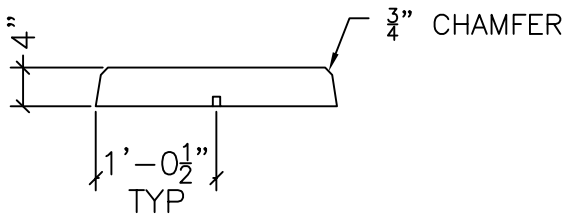

ELEVATION VIEW
 (SECTION A-A)

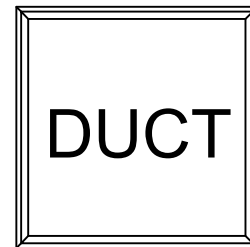

PLAN VIEW
 (TEXT EXAMPLE)