

MANHOLE

6'-0" x 10'-0" x 6'-0"

DESIGN CRITERIA:

CONCRETE: 5000 PSI @ 28 DAYS
 ENTRAINED AIR: 5% - 9%
 DESIGN LOADING: AASHTO HS20-44 WITH
 LESS THAN 2'-0" EARTH COVER
 REINFORCEMENT: BAR-ASTM A615 GR60
 WWR-ASTM A185/A497 GR65

****MAXIMUM DISTANCE FROM GRADE TO TOP OF BASE SLAB = 11'-0". EARTH COVER = 2'-0" MAXIMUM****

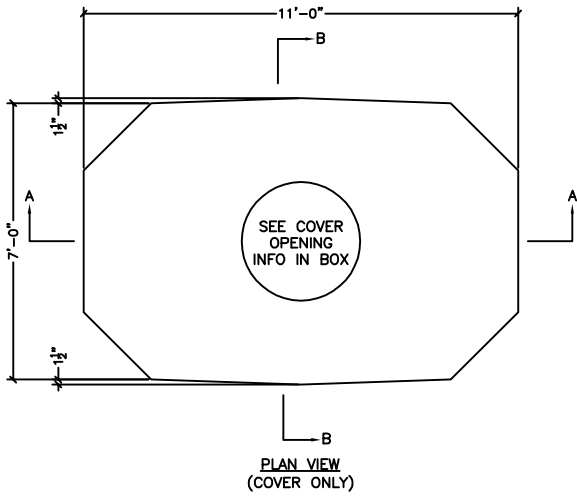

<input type="checkbox"/>	Ø30" COVER OPENING
<input type="checkbox"/>	Ø36" COVER OPENING
<input type="checkbox"/>	Ø48" COVER OPENING
<input type="checkbox"/>	OTHER

****COVER OPENING SIZES ARE STANDARD SIZES AND CENTERED IN THE PRECAST COVER. CUSTOM SIZES ARE AVAILABLE AT THE CUSTOMERS REQUEST. LOCATION CAN VARY.**

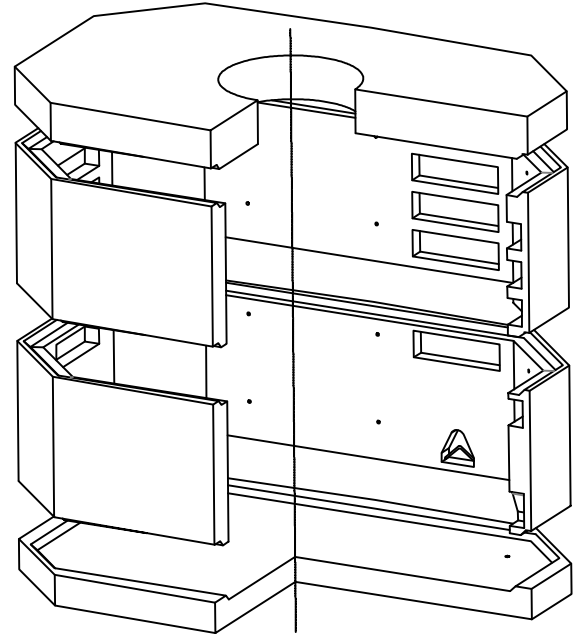

SPECIFICATIONS:

1. KNOCKOUTS SHOWN ARE STANDARD. VARIOUS KNOCKOUT TYPES ARE AVAILABLE, OPENINGS AS REQUIRED.
2. INSERT AND PULLING IRONS ARE STANDARD, CUSTOM QUANTITY AND LOCATION AS NEEDED
3. CAST IRON FRAME AND GRATES AVAILABLE FOR PURCHASE.

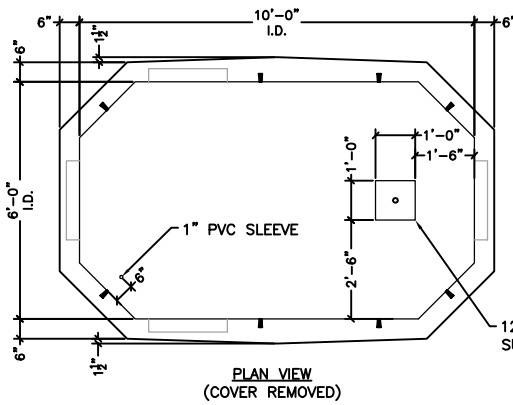

****WITH STOCK Ø36" OPENING**

COMPONENT	WEIGHT (LBS)
COVER	8894
BASE	7115
(2)36" RISER	6825
TOTAL	29659

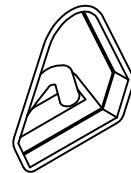

BOWCO INSERT PULLING IRON
 -NONCORROSIVE
 -SEVEN STRAND, 1/2"Ø, WITH AN ULTIMATE STRENGTH OF 270,000 PSI
 -ENCAPSULATED BY A RUSTPROOF SLEEVE THAT SLIPS OVER THE STEEL ROPE AT THE HOOKING POINT

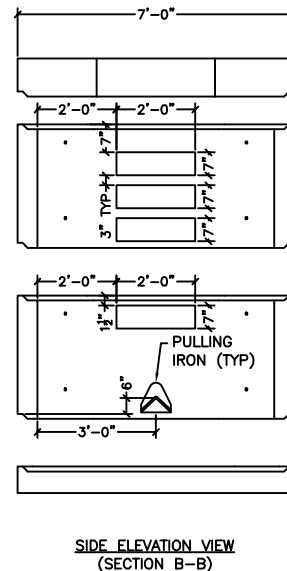
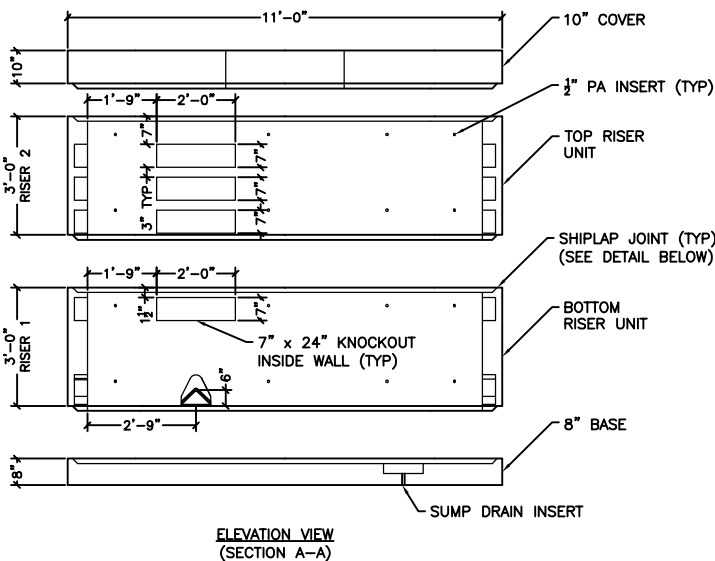

PENNSYLVANIA INSERTS
 -1/2" BOLT DIAMETER
 -STOPS CORROSION
 -2 1/2" BOLT EMBENDMENT DEPTH
 -WORK LOAD STRENGTH OF 1,260 LBS.

