



7520 EAST MAIN STREET, LIMA NY 14485  
 PH: 585-624-1990 - FAX: 585-624-2102  
 WEB: WWW.LAKELANDSCONCRETE.COM  
 E-MAIL: SALES@LAKELANDSCONCRETE.COM

DATE: 10/16/2020 DWG: CB484842

CATCH BASIN  
 4'-0" x 4'-0" x 3'-6"

**DESIGN CRITERIA:**

CONCRETE: 5000 PSI @ 28 DAYS  
 ENTRAINED AIR: 5% - 9%  
 DESIGN LOADING: AASHTO HS20-44 WITH LESS THAN  
 2'-0" EARTH COVER  
 REINFORCEMENT: BAR-ASTM A615 GR60  
 WWR-ASTM A185

**SPECIFICATIONS:**

1. CUSTOM KNOCKOUTS OR OPENINGS ARE AVAILABLE UPON REQUEST
2. FIELD/FRAME ADJUSTMENT SIZED PER CUSTOMERS REQUEST
3. BITUMASTIC COATING AVAILABLE IF REQUIRED
4. BOOTS/LINK SEALS PROVIDED IF REQUIRED (LAKELANDS MUST BE NOTIFIED)
5. SUMPS AS NEEDED BY CUSTOMERS REQUEST
6. CUSTOMER TO GROUT ANY KEYWAYS AS REQUIRED
7. CUSTOMER IS RESPONSIBLE OF THE FRAME INSTALLATION IN FIELD (IF REQUIRED)

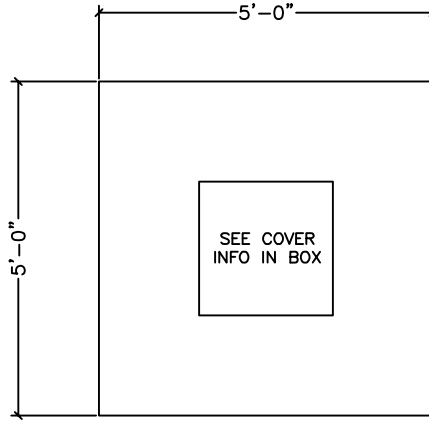

PLAN VIEW  
 OPTIONAL COVER ONLY

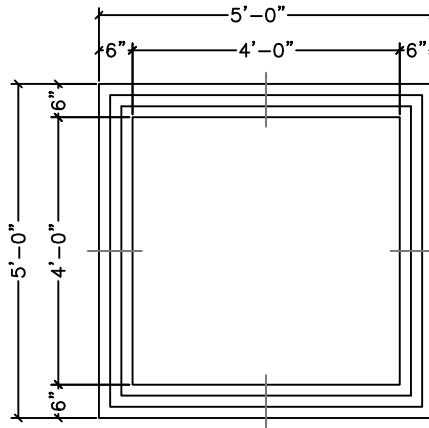

PLAN VIEW  
 OPTIONAL COVER REMOVED

COVER  
 OPENING SIZE: \_\_\_\_\_  
 NOT NEEDED

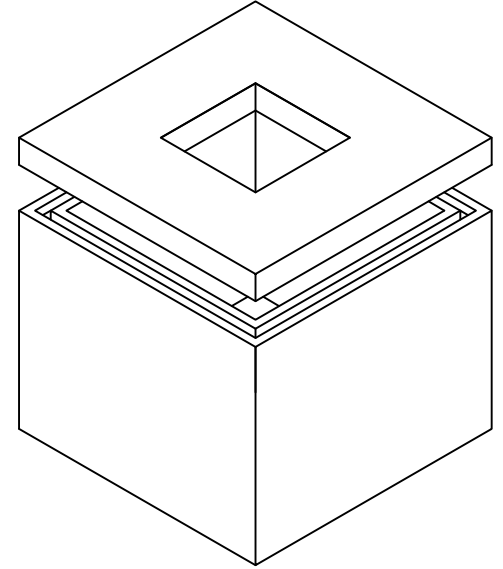

ISOMETRIC VIEW

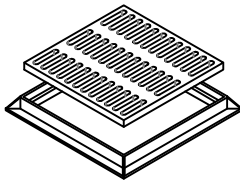

FRAME & GRATE

FRAME & GRATE  
 MODEL NO: \_\_\_\_\_  
 NOT NEEDED

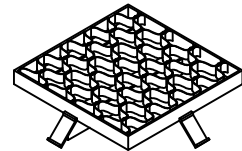

CAST-IN COLLAR FRAME AND GRATE

CAST-IN FRAME & GRATE  
 MODEL NO: \_\_\_\_\_  
 NOT NEEDED

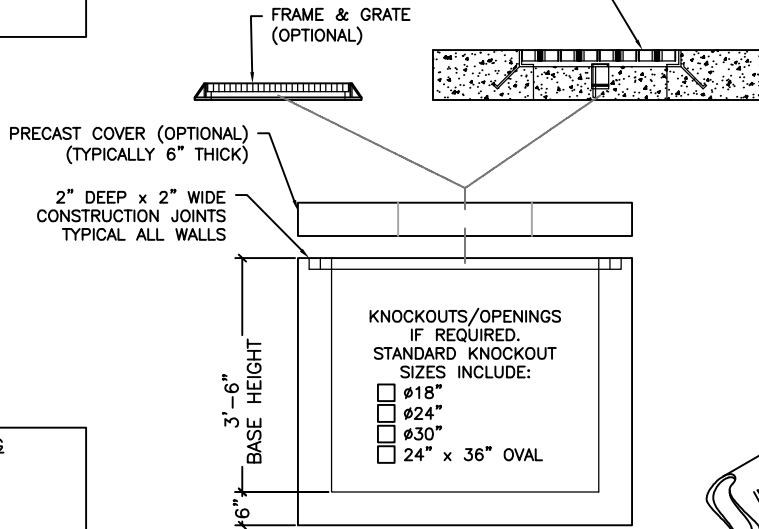

ELEVATION VIEW

**BITUMASTIC COATING**

EXTERIOR  
 INTERIOR  
 EXTERIOR AND INTERIOR  
 NOT NEEDED

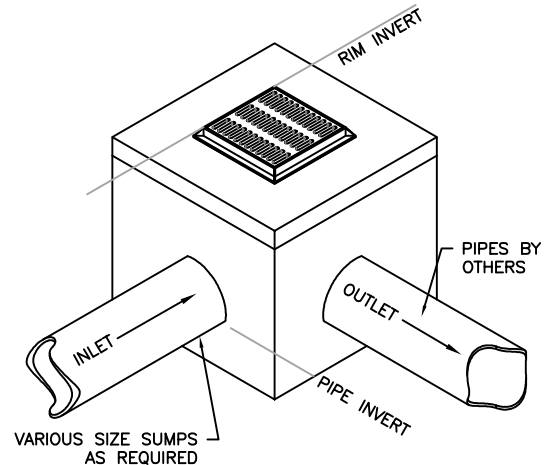

IN-FIELD VIEW

COMPONENT	SIZE	WEIGHT (LBS)
OPTIONAL COVER	STANDARD 24"x24" OPENING	1580
CATCH BASIN	42"	6600