



Lakelands Concrete Products, Inc.
7520 East Main St., Lima, NY 14485
Phone: 585-624-1990, Fax: 585-624-2102

Web: www.lakelandsconcrete.com
E-mail: sales@lakelandsconcrete.com

Date: 12/10/10

DWG: PB18D20

Stock Pullbox
18"Ø x 20"

PB18D20
PB18D20B

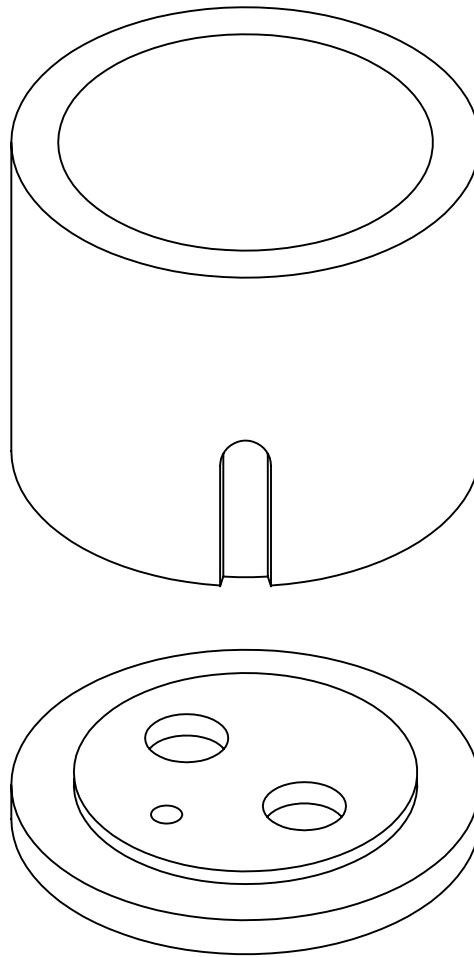



Lakelands Concrete Products, Inc.
 7520 East Main St., Lima, NY 14485
 Phone: 585-624-1990, Fax: 585-624-2102

Web: www.lakelandsconcrete.com
 E-mail: sales@lakelandsconcrete.com

Date: 12/10/10

DWG: PB18D20

Stock Pullbox
 18"Ø x 20"

Notes:

- *Cast Iron Frame And Covers Available
- *Knockouts Taper From 4 1/4" To 3 3/4"

PB18D20
 PB18D20B

Specifications:

Design Criteria: 5000 Psi @28 Days
 Entrained Air: 5% - 9%

Reinforcement: BAR-ASTM A615 GR60
 WWR-ASTM A185/A497 GR65

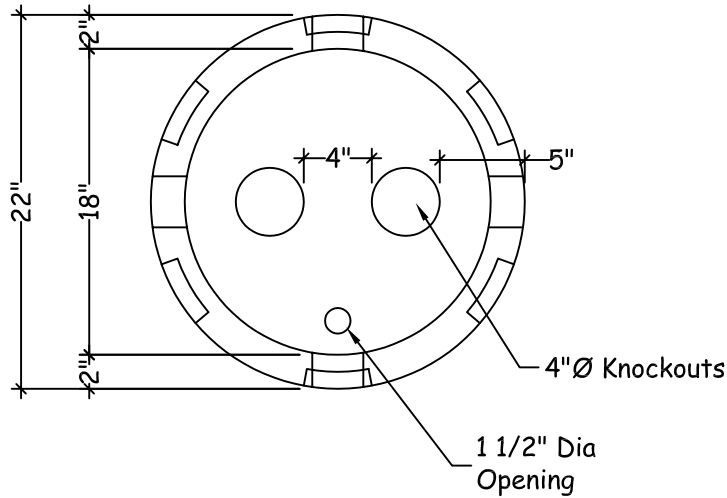

Plan View

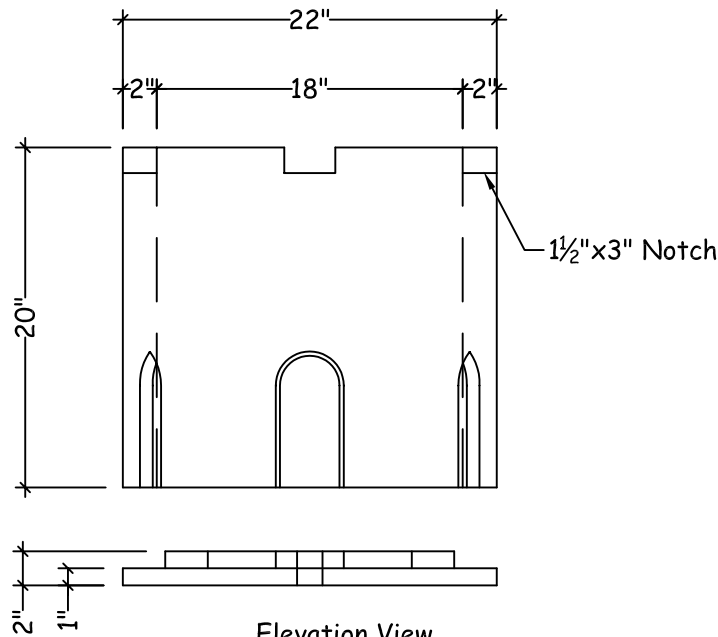

Elevation View

Weights:
 Box: 215lbs
 Base: 65lbs