



Lakelands Concrete Products, Inc.
 7520 East Main St., Lima, NY 14485
 Phone: 585-624-1990, Fax: 585-624-2102

Web: www.lakelandsconcrete.com
 E-mail: sales@lakelandsconcrete.com

Date: 12/15/10

DWG: TPMC100Cov

RG&E Standard
Precast Transformer Pads

Specifications:

Design Criteria: 5000 Psi @28 Days

Entrained Air: 5% - 9%

Reinforcement: BAR-ASTM A615 GR60

WWR-ASTM A185/A497 GR65

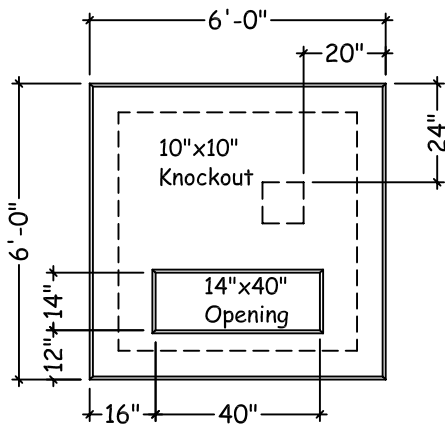

TPMC101 - 70-500 KVA

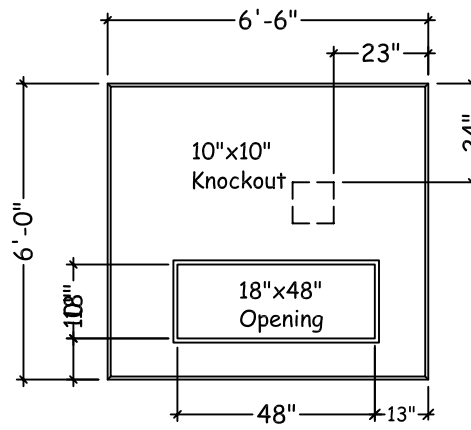

TPMC7278 - 750-1000 KVA

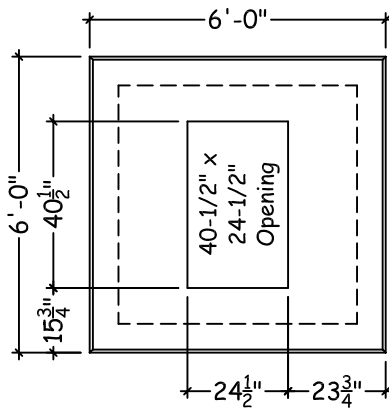

TPMC102M

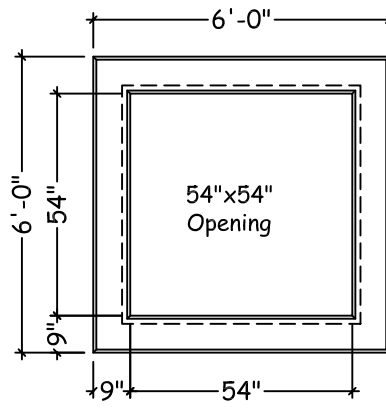

TPMC102

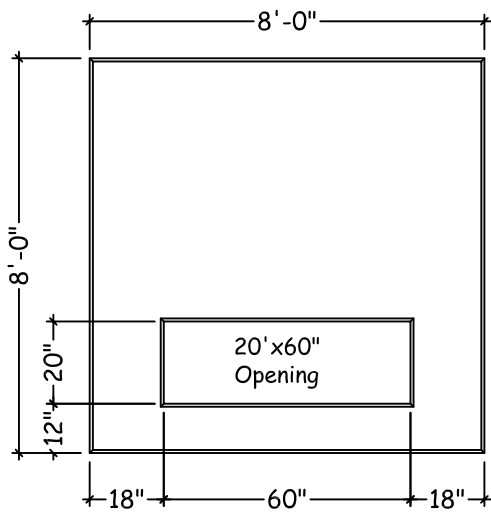

TPMC9696 - 1000-2500 KVA

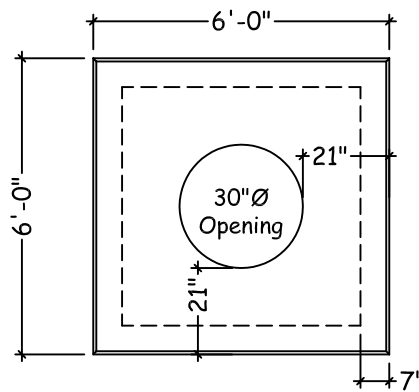

TPMC103

Weights:
 Pads: Heaviest Pad
 4200lbs