



Lakelands Concrete Products, Inc.  
7520 East Main St., Lima, NY 14485  
Phone: 585-624-1990, Fax: 585-624-2102

Web: [www.lakelandsconcrete.com](http://www.lakelandsconcrete.com)  
E-mail: [sales@lakelandsconcrete.com](mailto:sales@lakelandsconcrete.com)

Date: 2/2/01

DWG: GT3200

3200 Gallon  
Grease Trap

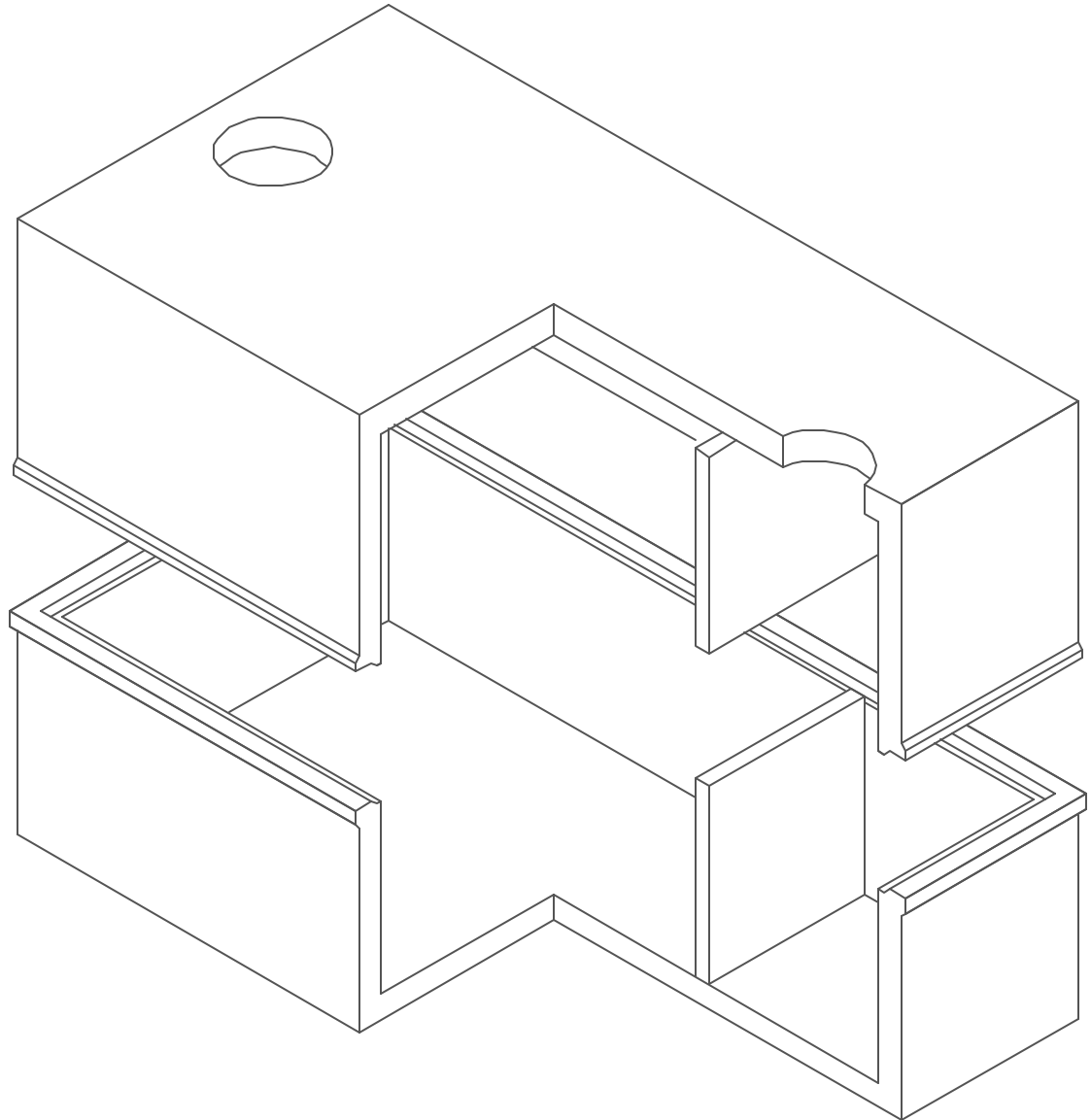



Lakelands Concrete Products, Inc.  
7520 East Main St., Lima, NY 14485  
Phone: 585-624-1990, Fax: 585-624-2102

Web: [www.lakelandsconcrete.com](http://www.lakelandsconcrete.com)  
E-mail: [sales@lakelandsconcrete.com](mailto:sales@lakelandsconcrete.com)

Date: 2/2/01

DWG: GT3200

### 3200 Gallon Grease Trap

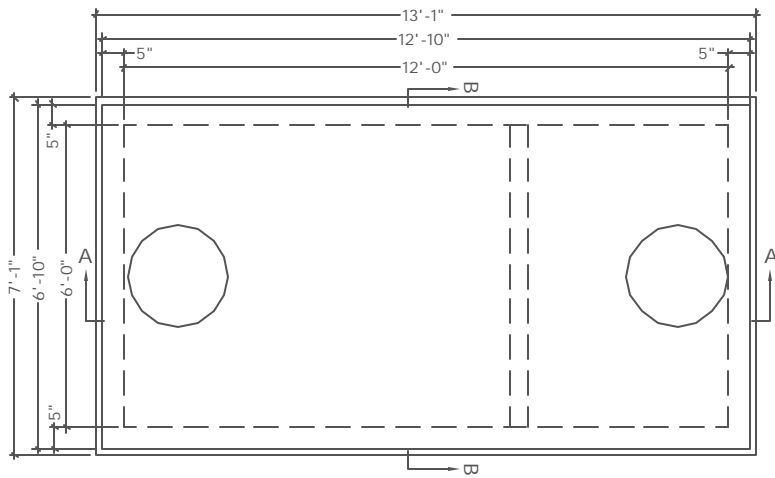

PLAN VIEW

#### Specifications:

Concrete: 5000psi @ 28 Days  
Entrained Air: 5% - 9 %  
Design Load: AASHTO HS20  
Reinforcing: fy= 60,000psi ASTM A615

#### Notes:

- \*Cast I Iron Frame And Covers Available
- \*Zabel Filter Model A300 Recommended
- \*Side Sections Are Adjustable, Vault Can Be Ordered In Various Heights

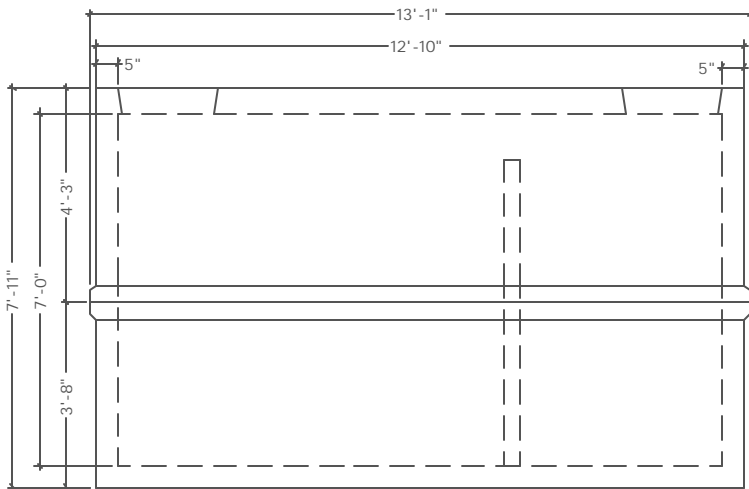

SECTION VIEW 'A'

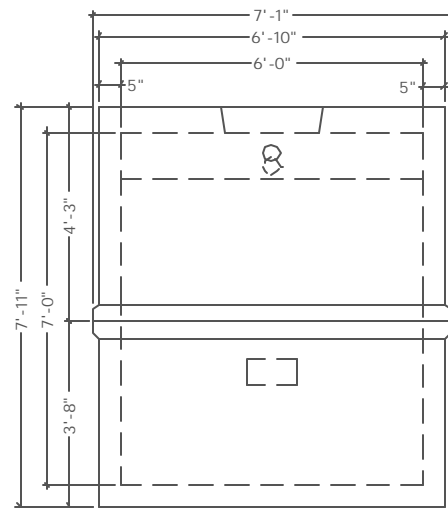

SECTION VIEW 'B'

#### Weight

Top: 16,800#  
Bottom: 14,100#