



Lakelands Concrete Products, Inc.  
7520 East Main St., Lima, NY 14485  
Phone: 585-624-1990, Fax: 585-624-2102

Web: [www.lakelandsconcrete.com](http://www.lakelandsconcrete.com)  
E-mail: [sales@lakelandsconcrete.com](mailto:sales@lakelandsconcrete.com)

Date: 2/2/01

DWG:BR-BC

Precast Concrete  
Box Culvert

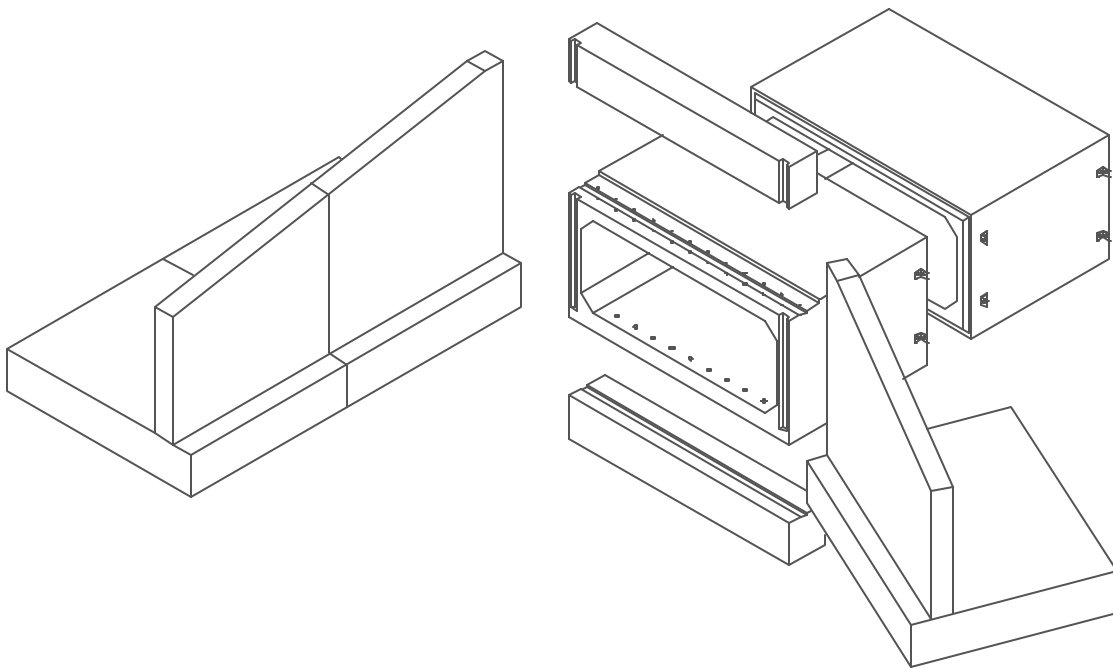



Lakelands Concrete Products, Inc.  
7520 East Main St., Lima, NY 14485  
Phone: 585-624-1990, Fax: 585-624-2102

Web: [www.lakelandsconcrete.com](http://www.lakelandsconcrete.com)  
E-mail: [sales@lakelandsconcrete.com](mailto:sales@lakelandsconcrete.com)

Date: 2/2/01

DWG:BR-BC

Precast Concrete  
Box Culvert

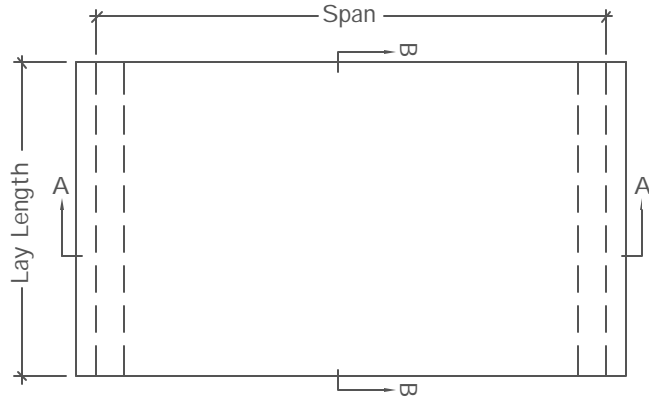

PLAN VIEW

Specifications:

Concrete: 5000psi @ 28 Days  
Entrained Air: 5% - 9%  
Design Load: AASHTO HS20,HS25  
Reinforcing:  $f_y = 60,000\text{psi}$  ASTM A615

Notes:

- \*Tapered And Skewed End Sections Available
- \*Maximum Lay Length Per Section = 7' - 6"
- \*Ship Lap Joints

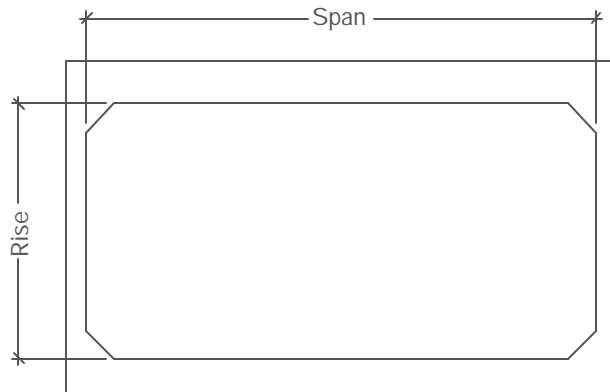

SECTION VIEW 'A'

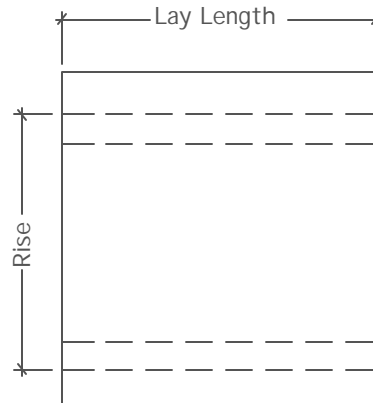

SECTION VIEW 'B'